

**WEATHERPROOF KEYPAD CODE 100
USER CODES
MODIFICATION OF THE PIN CODE BY THE USER**

Wiring diagram

V1, V2 - varistors

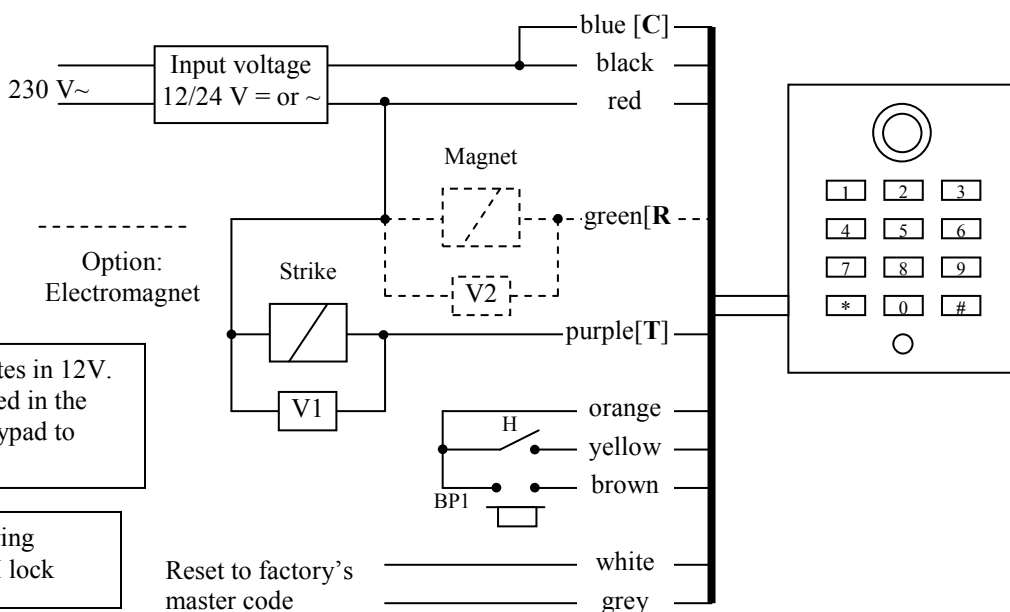

The keypad operates in 12V.
Cut the wire located in the
back top of the keypad to
operate in 24V.

See page 5 for wiring
diagram with E-M lock

Color	Correspondence
Black	Input voltage 12/24 V = or ~
Red	Input voltage 12/24 V = or ~
Blue	Relay common
Green	Relay normally closed
Purple	Relay normally open
Orange	Exit and timer (H) common
Yellow	Timer contact for external push button
Brown	Exit push button
White	Short circuit with the grey to restore the factory's master code
Grey	Short circuit with the white to restore to the factory's master code

This device comes with a varistor.

The varistor must be connected to the strike terminal (electromagnet...) operated by the device. If this product works with many strikes, each of them should have a varistor. The varistor controls the overload produced by the strike coil – self-effect.

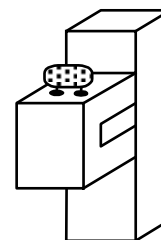

If you are using a « Shear Lock » electromagnetic lock, it is recommended to use a separate power supply than the one connected to the KCIE_100.

WIRING DIAGRAM AND INSTRUCTIONS



Technical specifications

Input voltage	12/24 V ~ or =
Output	1 relay N.O & N.C contact 6A/250V~
User codes	5-digit PIN code, 100 user codes programmable by keypad
Master code	5-digit master code
User modification code	2-digit user modification code
Exit push button	Request-to-exit push button and 1 external button (operated by the timer contact)
Keypad	12-digit keypad with built-in buzzer (audible signal)

Default values

Factory's master code:	12345
Relay time delay:	1 second in momentary output
Key-in keypad:	10 seconds
Programming delay:	120 seconds (2 minutes)

Code length

The master code and user codes must be 5-digits.

All the digit keys can be used to program a user code (0 to 9, *and #).

The master code cannot be used as a user code.

Code 00000 is used to delete an existing user code and then cannot be used as a user code.

External & Exit push buttons

The exit push button can be connected to activate the relay.

The timer contact enables to use the external push button:

timer contact open	- external push button disabled,
timer contact closed	- external push button enabled.

Audible signals

1 long beep	User code valid or validation of data in programming mode
2 short beeps	Entering into programming mode or exiting from programming mode
4 short beeps	Invalid user number or invalid code or invalid time delay



Setting a new Master Code

1. Enter the master code twice (for the first use the master code default value is 12345). 2 audible beeps confirm that you are in programming mode.
2. Enter *2 (modification number of the master code) then the new 5-digit master code. An audible beep indicates the validation of the code.
3. Press # to exit from the programming mode. 2 audible beeps confirm that you are back to Standby mode.

4 beeps indicate a data computing error.

Set the user codes and time delay

1. Enter the master code twice (for the first use the master code default value is 12345). 2 audible beeps confirm entry into programming mode.
2. Enter the user number to be programmed (from 00 to 99), and then the 5-digit user code (see programming board on the next page) an audible signal indicates the validation of the code.
3. Enter *1 (to set the relay time delay), then the time delay in seconds – 01 for 1 second up to 99 for 99 seconds. Enter 00 for a latched output.
4. Enter *0 (to set key-in keypad delay), then the time delay in seconds – 10 for 10 seconds up to 99 for 99 seconds, an audible signal indicates the validation of the code.
5. Enter *9 (to set the user modification code) then the 2-digit code, an audible signal indicates the validation of the code.
6. To exit from the programming at any time press #. 2 audible signals confirm that the keypad is now on standby.

4 beeps indicate a data error
The master code cannot be used as a user code.
The 00000 code is reserved for the cancellation of the existing user codes and therefore cannot be used as a user code.

Changing a PIN code by the user

1. Enter the user code. The relay is activated.
2. Enter **immediately** the 2-digit user modification code (for the first use the user modification code default is * and # or A and B). One beep sounds to confirm that you are in programming mode.
3. Enter the new user code twice. Two audible beeps indicate that the new user code is accepted.
4. Enter the new user code for testing it. The relay is activated.

If the new user code is not entered correctly, four beeps sound to confirm that the modification is not done.

Reset to the factory's master code

1. Short circuit the grey and the white wires
2. After 4 seconds the factory's master code (12345) replaces the old master code, which was memorized. An audible signal confirms the reset.
3. Separate and protect the grey and the white wires.

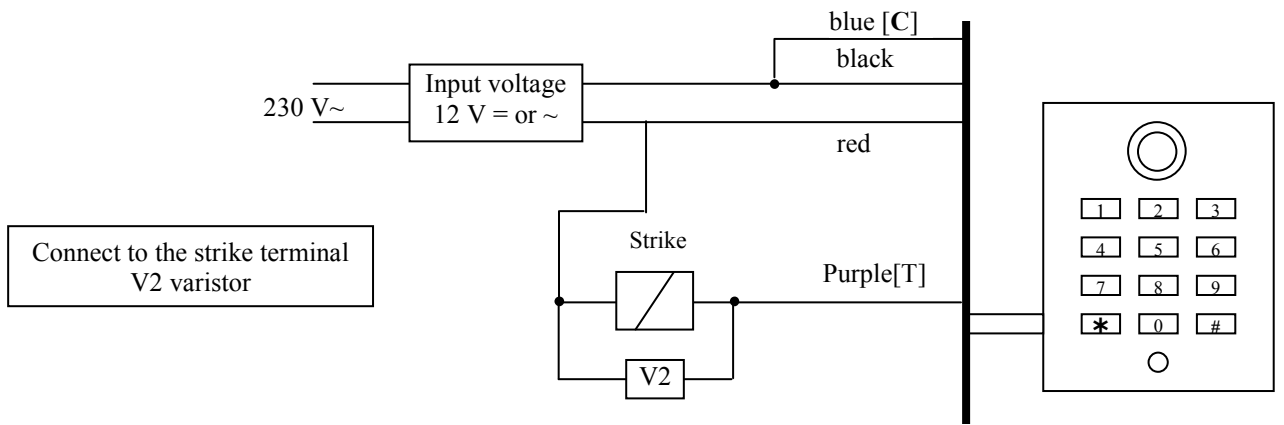

Blue	Common
Purple	N/O contact door relay
Green	N/C contact door relay



Template (real size)

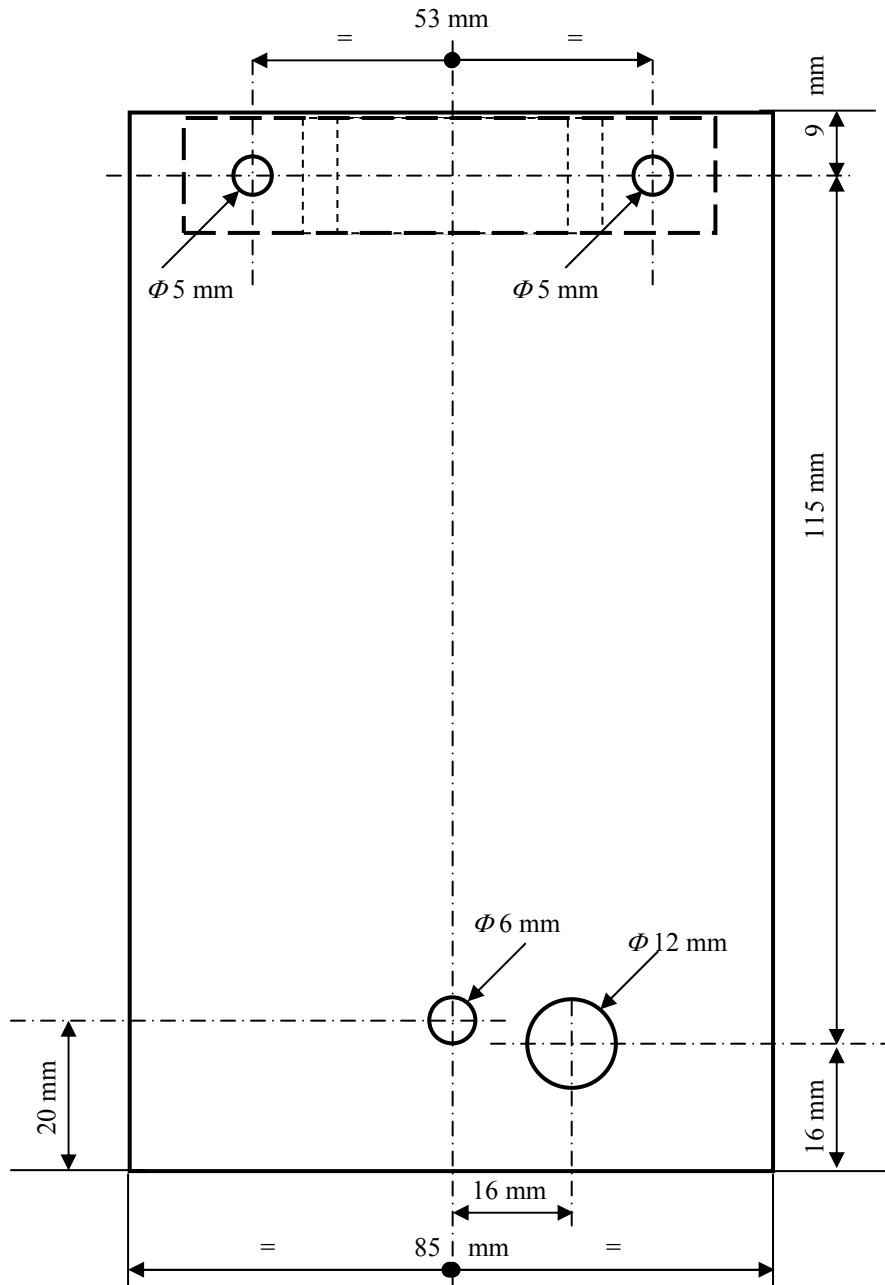

5 mm hole diameter
6 mm hole diameter
12 mm hole diameter

-To mount the hook support,
 -Hole for the brass anchor,
 -wiring access area.