

Installation Notes:

General description

This SD video door entry system is ideally suited to installations for single family properties or small offices. In the same range we offer systems with keypad built into the panel for access control and a choice of colour or mono options.

Cabling & Power

The system gets power from the mains fed via the video monitor. A 15V DC plug in power supply is provided with the kit. You may install this plug in power supply at a convenient location and extend its cable up to 20 metres.

If you are fitting a locking device you will need a power supply for that and we recommend fitting both units together.

External panel

This should be sited out of direct sunlight and not in exposed locations to avoid direct rain through the speaker grille.

The visitor is illuminated with bright 'white' light LEDs so that at night you are still able to see the image in colour for colour systems (IR for mono). The panel hood is secured to the wall with 2 screws. The camera assembly is secured to the hood with one screw underneath.

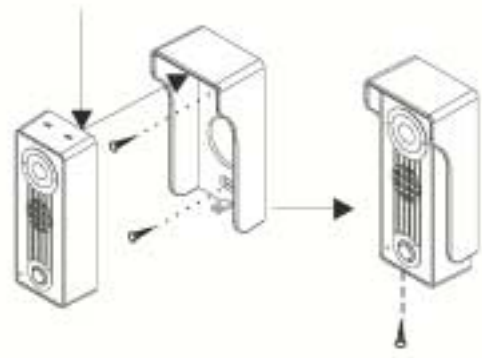

IMPORTANT
DO NOT OVER TIGHTEN
the panel fixing screw

Mount the panel at 1500mm from floor level.

Video monitor

The video monitor SD880RC16 colour and SD880R12S mono should be mounted at a height of approx. 1500mm above the floor level. The monitor has adjustments for ringer volume, brightness and contrast. In addition there are 3 buttons:

Monitor

The monitor button allows the user to light up the screen and see who is at the door without being called. If the handset is not lifted the screen will switch off after 30 seconds.

Call

The call button will ring any monitors on the system. If answered the monitors allow intercommunication without being over heard at the door panel.

Lock

Pressing the lock release button closes the switch L1 - L2. This voltage free switch can be directly connected to access control (egress input) or connected for electric lock by following the diagram below.

Trouble shooting

No Picture

Check the power adapter for the monitor
Check the contrast and / or brightness setting thumb wheel setting on the monitor
Check the wiring connections

Does not ring

Adjust the volume control thumb wheel

No Speech

Check handset is connected correctly
Check the wiring connections

Picture does not turn off

Turn power off, leave for 10 seconds then turn back on
Pick up handset then replace it

Poor Picture

Check specification of cable used against chart below.
Check position of 75Ω switches on the monitors

Optional additional monitors

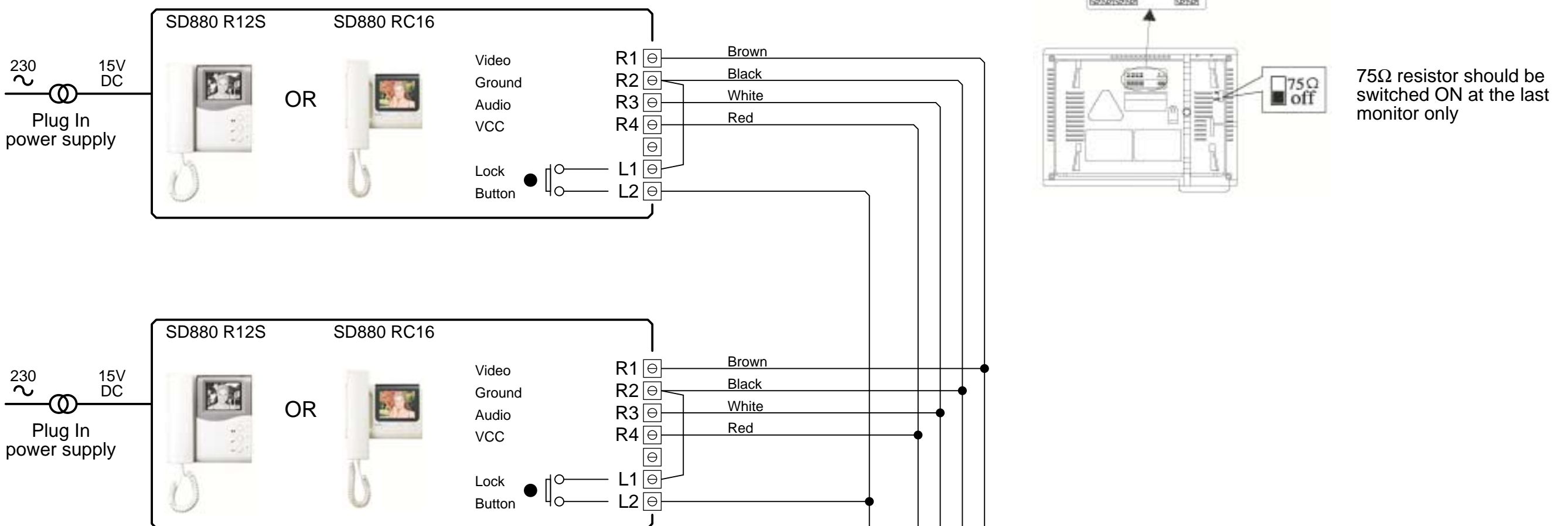

Contents of kit SDK-D1001 or SDK-DC1001

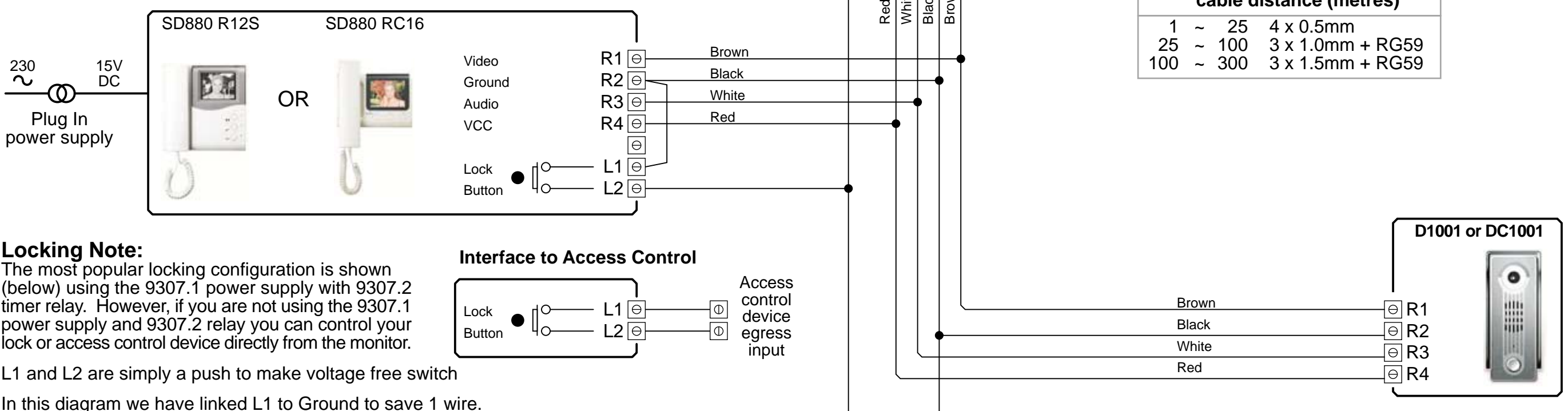

Locking Note:

The most popular locking configuration is shown (below) using the 9307.1 power supply with 9307.2 timer relay. However, if you are not using the 9307.1 power supply and 9307.2 relay you can control your lock or access control device directly from the monitor.

L1 and L2 are simply a push to make voltage free switch

In this diagram we have linked L1 to Ground to save 1 wire.

Add these components if you require

- 12V DC supply for locking device
- 12V AC supply for locking device
- Timed lock release relay
- Lock to monitor cable length greater than 25 metres

